

Tower System Media Filters

Carbon Tank System (CTS)

Carbon Steel Epoxy Coated Media Filters for Cooling Towers

CTS

Exceeds industry specifications for keeping cooling water systems free of troublesome contaminants. Removes particles and floating debris. Controls build-up in tower basins and remote sumps. Helps maintain optimum operating conditions for reduced maintenance, servicing, downtime, energy costs, water loss and enhances chemical performance.

LAKOS CTS Tower System Media Filters are designed exclusively for the demands of cooling tower operations. Filtration down to 5 micron is available as standard. Options for filtration down to 0.5 micron are available (consult factory). Either for side stream or full stream applications, Tower System Media Filters offer a full range of systems to meet your specific needs. High pressure ratings and ASME code options are available, please contact the factory.

Filtration efficiency of 90% removal by volume of particles down to 5 micron

Uniform, high porosity media for consistent, reliable performance at a low pressure loss.

Epoxy-coated carbon steel tanks

Durable, long-lasting and affordable.

Backwash options

Durable butterfly valves, mechanically linked via heavy-duty linkage rods operated by either pneumatic or electric actuators. Piping configurations for backwashing with system water or city/other water source.

Effective underdrain design

Encourages uniform flow through the sand media. Low pressure loss. Field-serviceable. Provides uniform backwashing for thorough media cleaning cycles. Prevents residual build-up and excessive backwash frequency.

Packaged Carbon Tank Systems (CTS) Include:

Filter vessel, valves, NEMA 4x - UL Listed Control Panel, end-suction single stage, TEFC motor; centrifugal pump (electric motor driven), and piping on a rigid skid. Standard 5 micron media is included as standard. Refer to page 2 for more details.



90-Inch Model Shown Here

Flow range:
192 - 1,006 U.S. gpm
(43 - 229 m³/hr)
*For higher flow rates,
consult factory*

Tank sizes:
42" to 96" diameter
@ 20 U.S. gpm/sq. ft.
(4.5 m³/hr)



LAKOS is a proud member of the U.S. Green Building Council

LAKOS

Separators and Filtration Solutions

Standard Configuration

Typical Side Stream Filtration Installations

Condensed Water Piping Side Stream Filtration

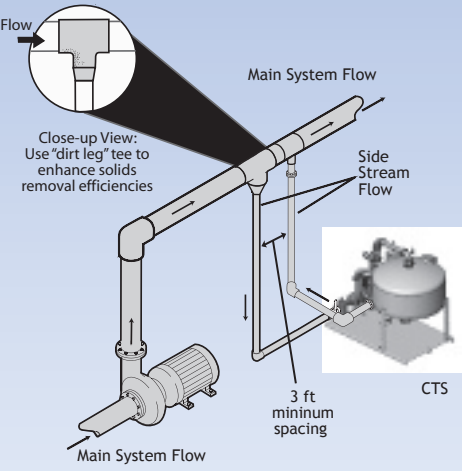

Cooling Tower Side Stream Filtration

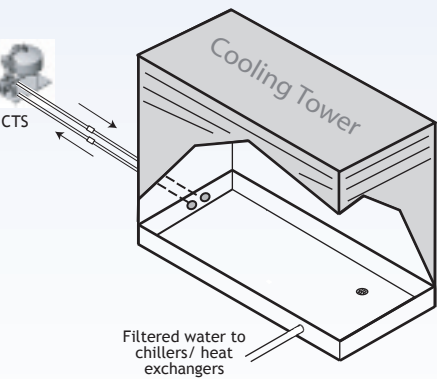

CTS System Diagram (CTS-48 and Smaller)

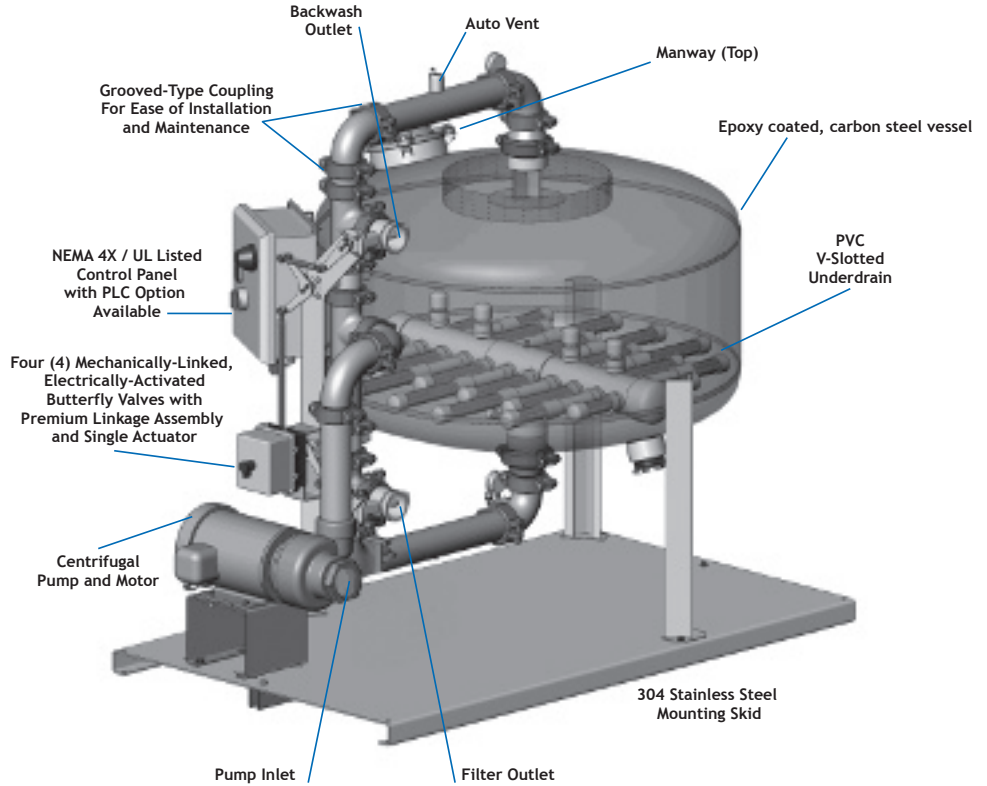

CTS System Diagram (CTS-54 and Larger)

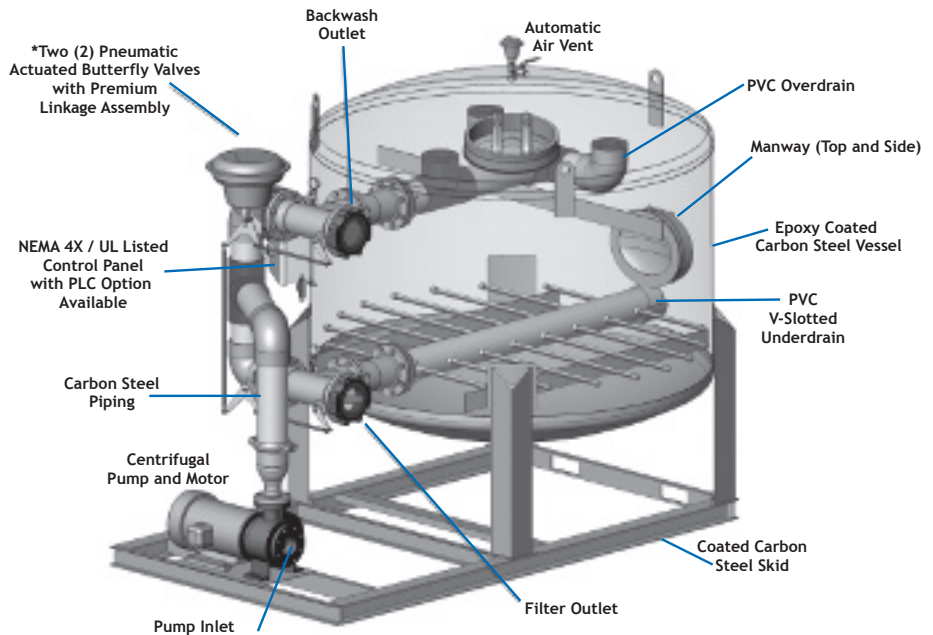

*CTS units up to the CTS-48 model have electrical actuators, while larger units have the pneumatic actuator shown above

How It Works

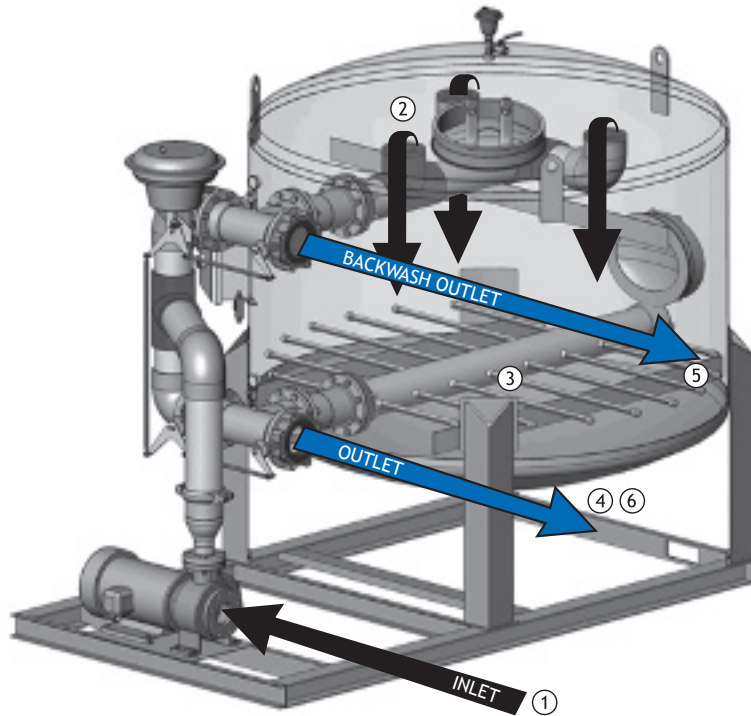

The Basic Steps of Media Filtration Operation

- ① Unfiltered system water enters pump INLET.
- ② Water is pumped to top and is uniformly dispersed over the media bed.
- ③ Water passes through the media bed, leaving debris behind.
- ④ Filtered water exits the OUTLET.
- ⑤ The media bed is cleaned through a backwash cycle at specified intervals or differential pressure. The backwash cycle runs for 3 minutes.
- ⑥ System returns to normal filter mode.

for 42"-48" Tanks

General Specifications

CTS Filter Model	Pump H.P.	Pump Inlet	Surface Area Sq. Ft.	Flow Rate @ 20 GPM/Sq. Ft.	Media Loading (Cu. Ft.)		Weight (lbs.)			
					MediaGem475	MediaGem55	Filter	Media	Shipping	Operating
CTS-42-192	5	3 NPT	9.62	192	—	11.0	1015	1100	2115	3629
CTS-48-252	5	3 NPT	12.6	252	—	13.0	906	1300	2206	4129

*For filtration down to 2 microns, consult LAKOS.

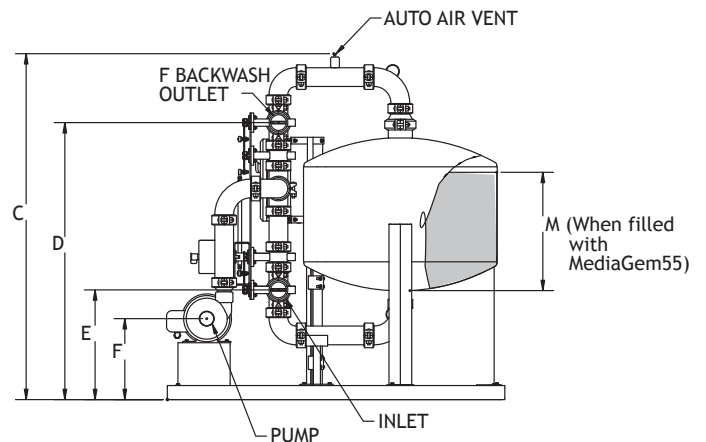
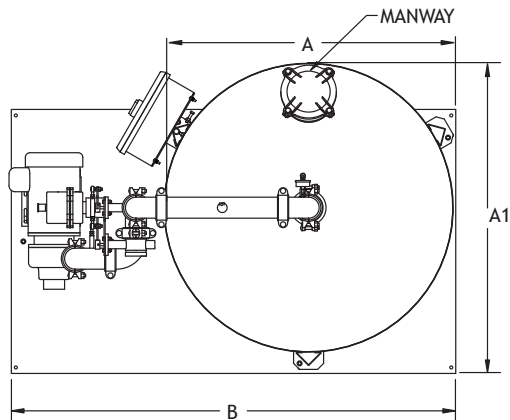

Dimensions

CTS Filter Model	A	A1	B	C	D	E	F	M
CTS-42	42.00	46.38	69.00	66.75	51.38	20.13	15.13	21.13
CTS-48	48.00	55.81	74.00	66.75	51.38	20.13	15.13	21.50

General Specifications

CTS Filter Model	Pump H.P.	Pump Inlet	Surface Area Sq. Ft.	Flow Rate @ 20 GPM/Sq. Ft.	Media Loading (Cu. Ft.)		Weight (lbs.)			
					MediaGem475	MediaGem55	Filter	Media	Shipping	Operating
CTS-54-318	7.5	4 FLG	15.9	318	18.00	34.00	2339	5434	7773	12,215
CTS-60-392	7.5	5 FLG	19.6	392	23.00	42.00	2716	6758	9474	14,993
CTS-66-474	10	5 FLG	23.8	474	29.00	51.00	2962	8397	11,359	18,209
CTS-72-566	10	5 FLG	28.3	566	37.00	64.00	3362	10,374	13,736	22,444
CTS-78-664	15	5 FLG	33.2	664	47.00	75.00	3752	12,261	16,013	26,855
CTS-84-770	15	6 FLG	38.5	770	56.00	87.00	4216	14,783	18,999	31,296
CTS-90-884	15	6 FLG	44.2	884	68.00	100.00	4345	17,346	21,691	36,088
CTS-96-1006	20	6 FLG	50.2	1006	81.00	136.00	6034	22,430	28,464	42,654

*For filtration down to 2 micron, consult your LAKOS representative.

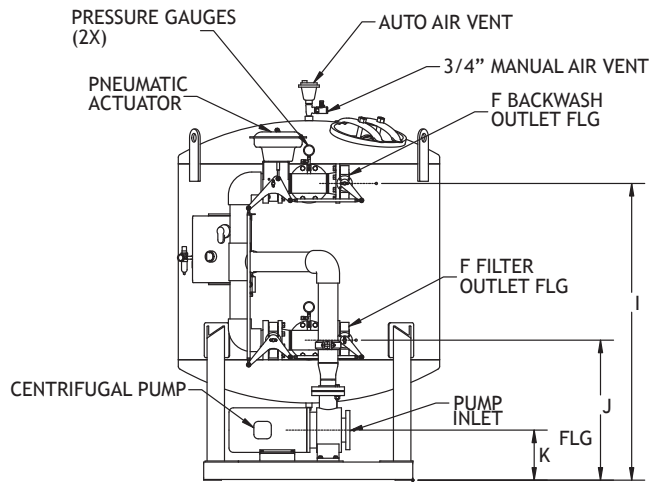
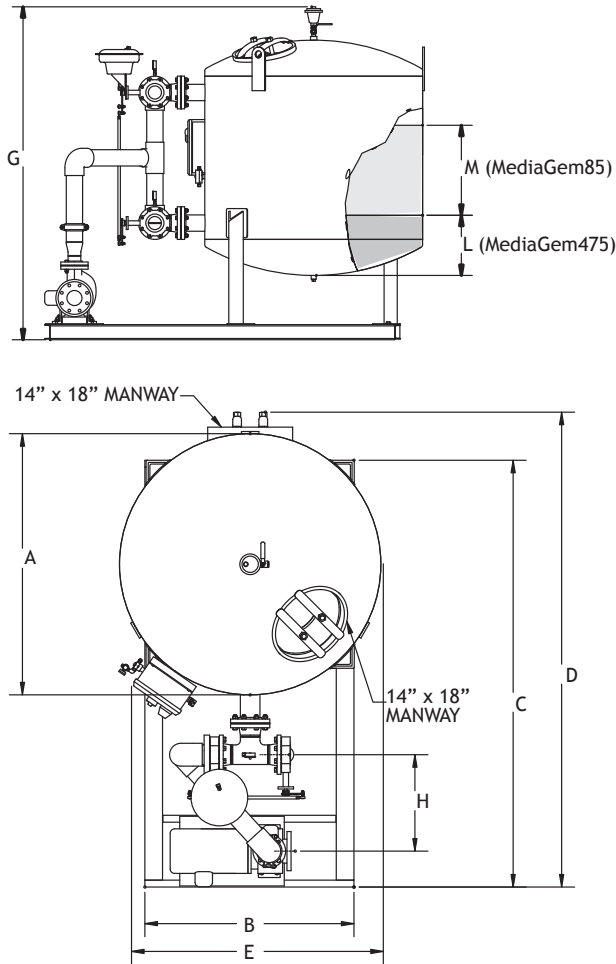

Dimensions

CTS Filter Model	A	B	C	D	E	F	G	H	I	J	K	L	M
CTS-54	54	43.50	93.00	102.69	61.19	4.00	91.00	19.69	68.19	32.19	11.50	17.06	25.66
CTS-60	60	48.00	98.00	108.88	62.00	4.00	91.75	19.69	68.19	32.19	11.50	17.06	25.71
CTS-66	66	52.00	103.00	114.88	66.19	4.00	93.50	19.81	68.19	32.19	11.50	17.06	25.71
CTS-72	72	56.38	106.00	118.75	72.00	6.00	96.50	15.38	69.19	33.19	12.81	20.32	27.13
CTS-78	78	60.50	113.00	126.63	78.00	6.00	97.25	17.25	69.19	33.19	12.81	20.32	27.10
CTS-84	84	66.50	118.18	131.81	84.00	6.00	103.88	18.94	75.19	39.19	14.19	20.32	27.11
CTS-90	90	71.00	126.18	140.69	90.00	6.00	105.69	20.69	76.19	40.19	14.19	20.32	27.14
CTS-96	96	77.50	142.50	156.75	96.00	8.00	115.69	25.56	84.38	43.38	16.38	22.72	32.50

Basin Sweeping Options

CTS-SWP System Diagram

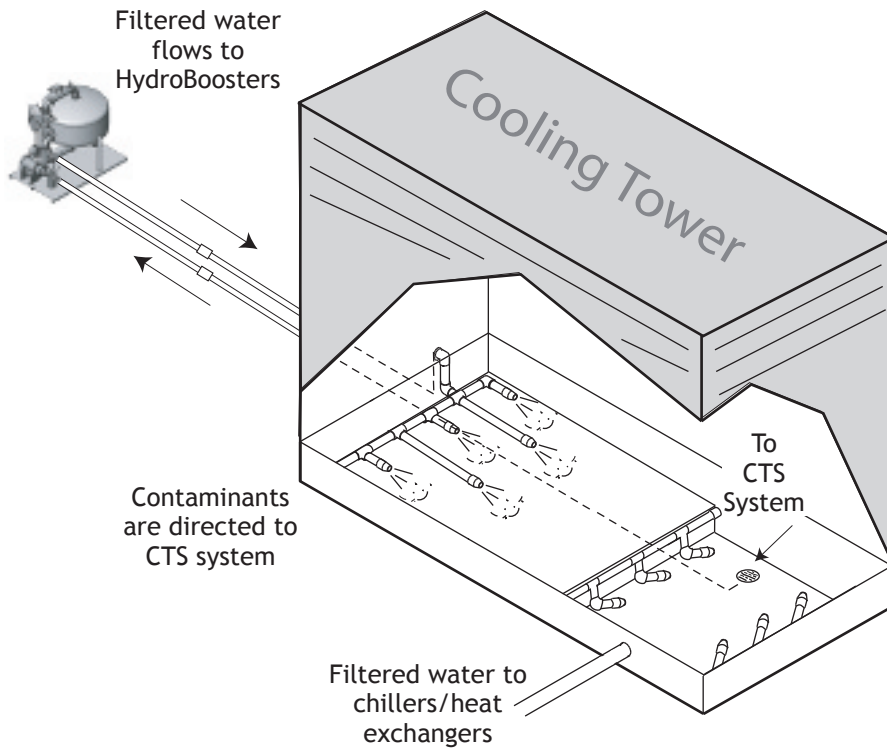

LAKOS Offers CTS-SWP Systems For Basin Sweeping With Higher Head (Pressure) Pumps. Consult LAKOS for the Appropriate Pump (Head and Horsepower) Selection for Your Application.

HydroBoosters

Directed turbulence maximizes cleaning efficiency in the tower basin/remote sump. LAKOS HydroBoosters provide turbulence with patented vortexing action as shown. Swivel clips are available as shown in the picture below. Many cooling tower manufacturers offer factory-installed basin sweeping piping. Please consult LAKOS for proper equipment selection. Backwash/Holding tank options available - consult your LAKOS representative.

Model	Connection Size (inches)	Extension Size (minimum)	Flow Input and Output
HB-10-K	3/4" male NPT	3/4"	10 US gpm and 60 US gpm 2 m ³ /hr and 12 m ³ /hr
HB-18-K	3/4" male NPT	1"	18 US gpm and 108 US gpm 4 m ³ /hr and 24 m ³ /hr
HB-35-K	1" male NPT	1 1/4"	35 US gpm and 210 US gpm 8 m ³ /hr and 48 m ³ /hr
*TSN-0025-B	1/4" male NPT	—	4.2 US gpm 1 m ³ /hr

Flow boosted to 6 U.S. gpm through HydroBooster

1 U.S. gpm enters HydroBooster

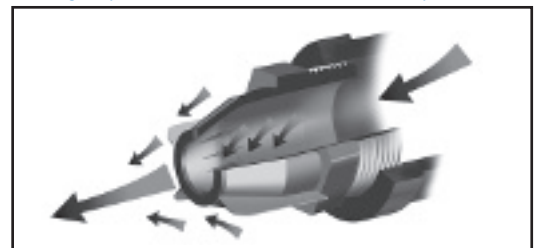

HydroBoosters in action

NOTE: These flow rates are based on an input pressure of 20 psi (1.4 bar)
Minimum water level above centerline of HydroBooster should be 2 inches

* This is a flat-fan spray nozzle (brass) for use in applications with a shallow deck in the basin. May be combined with HydroBoosters

Basic Specifications

Limited Warranty

All products manufactured and marketed by this corporation are warranted to be free of defects in material or workmanship for 12 months from date of installation; if installed 6 months or more after ship date, warranty shall be a maximum of 18 months from ship date.

If a fault develops, notify us, giving a complete description of the alleged malfunction. Include the model number(s), date of delivery and operating conditions of subject product(s). We will subsequently review this information and, at our option, supply you with either servicing data or shipping instruction and returned materials authorization. Upon prepaid receipt of subject product(s) at the instructed destination, we will then either repair or replace such product(s), at our option, and if determined to be a warranted defect, we will perform such necessary product repairs or replace such product(s) at our expense.

This limited warranty does not cover any products, damages or injuries resulting from misuse, neglect, normal expected wear, chemically-caused corrosion, improper installation or operation contrary to factory recommendation. Nor does it cover equipment that has been modified, tampered with or altered without authorization.

No other extended liabilities are stated or implied and this warranty in no event covers incidental or consequential damages, injuries or costs resulting from any such defective product(s).

1365 North Clovis Avenue
Fresno, California 93727 USA
Telephone: (559) 255-1601
FAX: (559) 255-8093
Toll Free: (800) 344-7205
(USA, Mexico and Canada)
Internet: www.lakos.com
E-mail: info@lakos.com

Filtration Type & Performance

The removal of specific unwanted contaminants from a pumped/pressurized fluid flow system shall be accomplished with a sand media filtration package. Performance shall be specified for particulate as fine as 2 microns, based on the specific sand media supplied.

Filtration System Design & Function

System shall be designed/sized for a flow rate of 20 gallons per minute per square foot of filter media surface area.

A system-matched pump directs the fluid through a butterfly valve into the inlet of a sand media filter tank. Flow is evenly distributed across the sand media bed, allowing the fluid to pass through the sand media and capturing the contaminants on the surface and upper layer of the sand media. Fluid flow continues through the sand media to the filter tank's integral underdrain, directing water to the filter system's outlet.

The underdrain shall feature a full-size manifold with serviceable removal lateral design to ensure that filter flow and backwash flow are uniform across and throughout the sand media bed.

Each unit shall be equipped with a man-way located on the top of the unit, and on the tank side. A pressure gauge and air relief assembly shall also be provided.

Backwashing/Contaminant Removal

The accumulation of contaminants on the sand media surface shall be monitored via pressure differential from inlet to outlet. At a prescribed pressure differential or a given period of time or operator discretion, the filter system shall backwash the captured contaminants to desired waste. This function shall be a) automatically controlled via a pressure differential gauge and clock timer, or b) manual, monitored and initiated by an operator.

The butterfly valve at the inlet shall be actuated pneumatically or electrically to interrupt system flow and provide a backwash discharge outlet. Backwash flow shall come from either a) the system flow, redirected through filter tank's outlet and underdrain, or b) a separate flow source, such as city water, directed through the filter tank's outlet and underdrain.

Backwash flow and pressure shall be sufficient to fluidize the sand media bed and cause the surface contaminants to rise in suspension and discharge via the flanged butterfly valve to desired waste.

Upon completion of the backwashing cycle, the inlet's butterfly valve shall again return to its operating position, allowing system flow to enter the filter tank, simultaneously interrupting backwash discharge. This allows the sand media bed to again settle, forming the filtration surface for further contaminant removal.

Filter System Details

A. Inlet shall be flanged 150# or grooved rated size: _____

B. Outlet shall be flanged 150# or grooved rated connection, size: _____

C. Backwash discharge outlet shall be flanged 150# or grooved rated connection, size: _____

D. Backwash supply line (if not using redirected system flow) shall be flanged 150# or grooved rated connection, size: _____

Lakos Separators are manufactured and sold under one or more of the following U.S. Patents: 5,320,747; 5,338,341; 5,368,735; 5,425,876; 5,571,416; 5,578,203; 5,622,545; 5,653,874; 5,894,995; 6,090,276; 6,143,175; 6,167,960; 6,202,543; 7,000,782; 7,032,760 and corresponding foreign patents, other U.S. and foreign patents pending.

E. The filter system shall operate at a flow rate of: _____

Filter System Construction

Filter tank - ASTM-carbon-steel, all welded construction, with flanged or grooved inlet / outlet, threaded drain and air release connections. Tank shall be suitable for a working pressure of 80 psi on 48" and smaller, and 50 PSI on 54" and larger. Higher pressure rating and/or ASME Code available as an option. The tank will be provided with an epoxy interior lining and two coats of enamel paint on the exterior.

Overdrain/Underdrain - Schedule 80 PVC pipe.

Piping:

CTS-48" and smaller - Galvanized steel with grooved coupling.

CTS-54" and larger - Carbon steel welded.

Pump - End-suction, single stage; TEFC motor; cast iron housing; iron impeller; bronze shaft sleeve; BUNA-N mechanical shaft seal. Pump to be rated for 20 gallons per square foot of filter media surface area at 50 feet TDH. Flooded suction required.

Backwash valves - Butterfly valves; Ductile iron bodies; EPDM valve seats; 416 series stainless steel shaft; Nickel plated ductile iron disc. Valves shall be mechanically linked via heavy duty linkage rods.

Actuator are as follows:

Pneumatic - Actuators shall be driven by floating stem pneumatic actuator with spring return diaphragm for fail safe operation (CTS-54 & larger). A minimum 15 psi air supply is required for operation.

Electrical - Actuators shall be electric and shall incorporate an electric brake to prevent back-drive (CTS-42 & CTS-48).

Pressure Gauges - The filter shall have inlet and outlet pressure gauges.

Control Panel - IEC starter with overload module; HOA selector switch; NEMA-4X enclosure; UL listed; re-set/disconnect/trip switch; 120 volt, single phase control voltage; manual backwash switch; pressure differential switch (factory set to backwash filter); backwash cycle timer; 24-hour backwash clock.

Filter media:

Multi Media (standard) - Filtration efficiency of 90% removal by volume of particles 5 micron and larger (MediaGem 475 + MediaGem 55).

Multi Media (optional) - Filtration down to 0.5 micron consult factory for system design/selection based on specific application and filtration efficiency.

Skid - Carbon steel with epoxy coating (CTS-54 & larger).

StainlessSteel - 3/16-inch minimum thickness (CTS-42 & CTS-48)

PLC Option - Allen Bradley "Pico" PLC (Standard)

- Programmable logic relay
- Pre-programmed at factory
- Can be programmed for multiple operating/monitoring functions

Consult Lakos for applications and more information.